

# 100-47SJ

## CAPABILITY

- 100' working height
- 47' horizontal reach
- 440 lbs lift capacity
- Triple position swing-out outriggers

## STANDARD FEATURES

- Wireless remote control
- AC power to basket
- Outriggers control from wireless remote
- Air-Water line to basket
- Lightweight aluminum detachable basket
- Proportional controls
- Hydraulic basket rotator
- Hour meter
- Movement alarm
- Manual emergency descent system
- Long travel outriggers

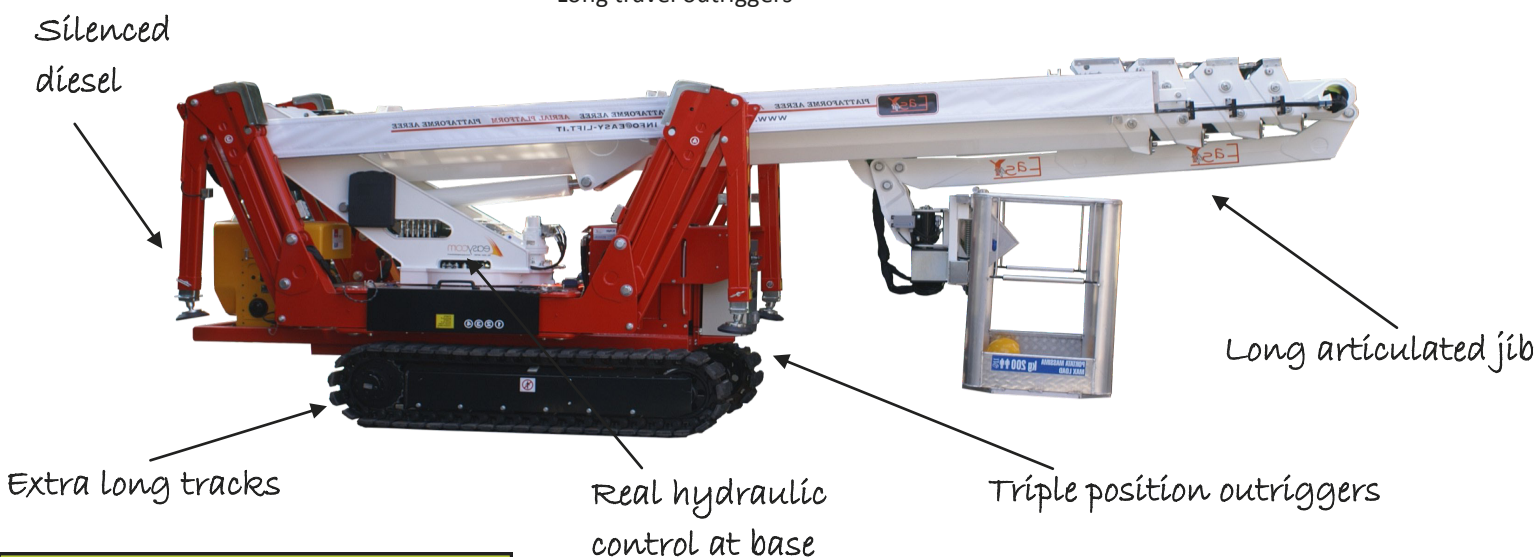

## MANY CONFIGURATIONS FOR YOUR NEEDS

- Hatz diesel + electric AC motor
- Lithium Ion battery + ultra fast charger
- Hatz diesel + Lithium Ion

## OPTIONS AND ACCESSORIES

- Emergency descent electric pump 12V
- Automatic self leveling for outriggers
- Non-marking soft rubber tracks
- Special painting
- Working lamp on basket
- Outriggers "sinking" alarm
- Teflon pads kit (4) for stabilizers
- Strobe light (beacon)
- Casters on basket
- Winter start package
- Hostile Kit

## PRODUCTIVITY

- Top mount lifting points
- High speed operational boom
- Variable outriggers pattern for adaptability
- Standard boom raising enable while driving
- High departure angle for climbing

## SAFETY

- Basket anti over-load redundant sensors
- Active envelope stability management system with redundant sensors
- Easy to read operational pilot lamps
- Wind safe up to 28Mph (45Kph)
- Solid state simple electrical components
- Proportional hydraulic joystick controls for intuitive and precise boom movements
- Smooth and automatic basket leveling
- Harness anchor points

## RELIABILITY

- High tensile steel boom Domex SSAB
- Standard high quality components like Sauer Danfoss, Telemecanique, Finder
- External power track for easier inspection and replacement of components
- External adjustable telescopic boom wear pads; no shimming required
- Greasable fittings in all pivot points
- High quality powder coat paint

# 100-47SJ

## WORKING AREA

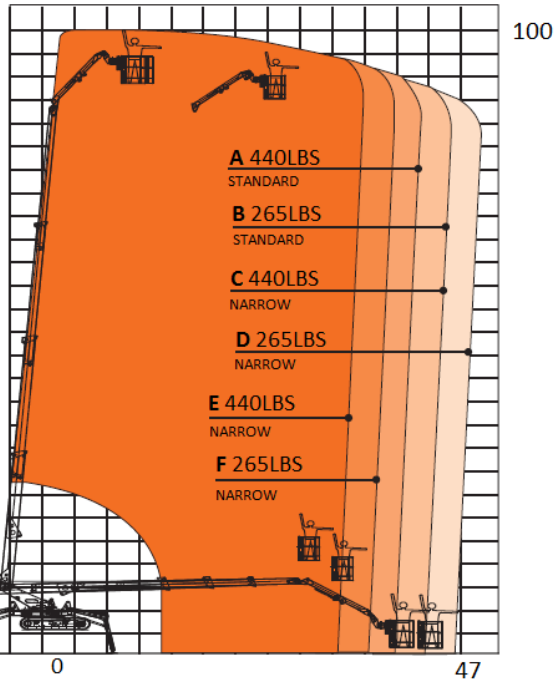

## DIMENSIONS

• Working height	100'
• Basket capacity at full height	440 lbs
• Maximum horizontal side reach	
with 265 lbs	47'- 0"
with 440 lbs	42'- 7"
• Length	22'- 0"
• Minimum width	55"
• Basket dimensions (L x W x H)	79" x 28"
• Turret rotation	360 degrees
• Max slope travel ability	17 Deg or 32%
• Outriggers footprint	
	Standard 12'- 6" x 12'- 6"
	Narrow 1 10'- 6" X 14'- 7"
	Narrow 2 14'- 7" X 10'- 6"
• Total weight diesel	13 227 lbs

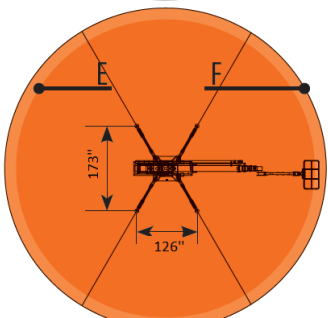
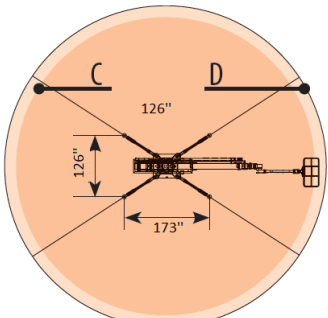
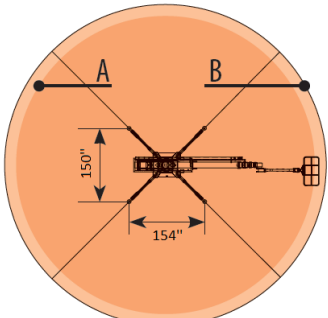
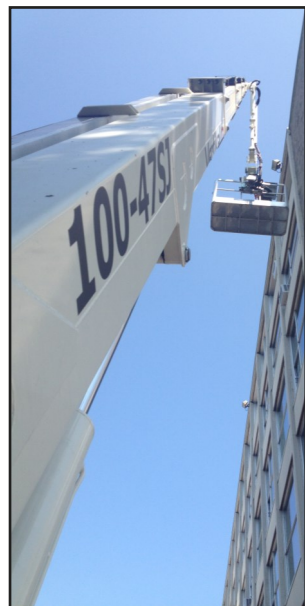

## SIDE VIEW

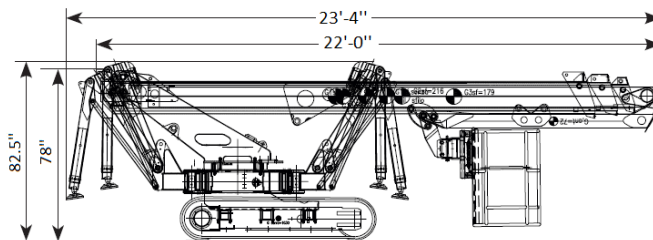

## TOP VIEW

