

50-28AJ

CAPABILITY

- 50' working height
- 28' horizontal reach
- 440 lbs lift capacity
- Full reach at maximum basket capacity

STANDARD FEATURES

- Lightweight aluminum detachable basket
- Movement alarm
- Black deep tread rubber tracks
- Articulated jib operational at full capacity
- AC power to basket
- Air-Water line to basket
- Proportional controls
- Hour meter
- Manual emergency descent system

OPTIONS AND ACCESSORIES

- Emergency descent electric pump 12V
- Hydraulic basket rotator
- Automatic self leveling for outriggers
- Wired or Radio remote control
- Non-marking soft rubber tracks
- Hydraulic variable width tracks
- Special painting
- Working lamp on basket
- One Man fiberglass basket
- Two Men fiberglass basket
- Outriggers "sinking" alarm
- Teflon pads kit (4) for stabilizers;
- Strobe light (beacon)
- Winter start kit
- Hostile Kit

MANY CONFIGURATIONS FOR YOUR NEEDS

- Honda gas + electric AC motor
- Hatz diesel + electric AC motor
- Honda propane + electric AC motor
- Tri-fuel; gas/propane/electric AC
- Lithium Ion battery + ultra fast charger
- Lithium Ion + gas engine + AC
- Lithium Ion + gas + propane + AC

PRODUCTIVITY

- Top mount lifting points for crane
- Tie down points
- 5 feet articulated jib @ 440 lbs
- High departure angle for climbing
- High speed operational boom
- Standard jib raising enabled while driving

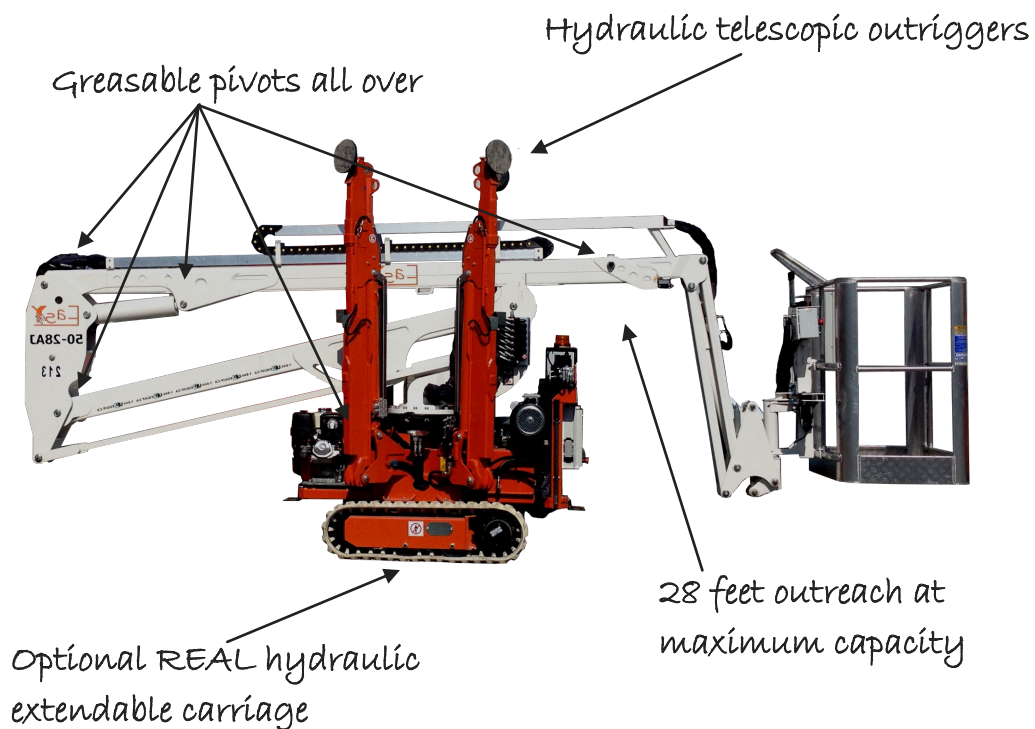

SAFETY

- Active envelope stability management system with redundant sensors
- Easy to read operational pilot lamps
- Wind safe up to 28Mph (45Kph)
- Solid state simple electrical components
- Proportional hydraulic joystick controls for intuitive and precise boom movements
- Smooth and automatic basket leveling
- Harness anchor points

RELIABILITY

- High tensile steel boom Domex SSAB
- Standard high quality components like Sauer Danfoss, Telemecanique, Finder
- External power track for easier inspection and replacement of components
- External adjustable telescopic boom wear pads; no shimming required
- Greasable fittings in all pivot points
- High quality powder coat paint

50-28AJ

WORKING AREA

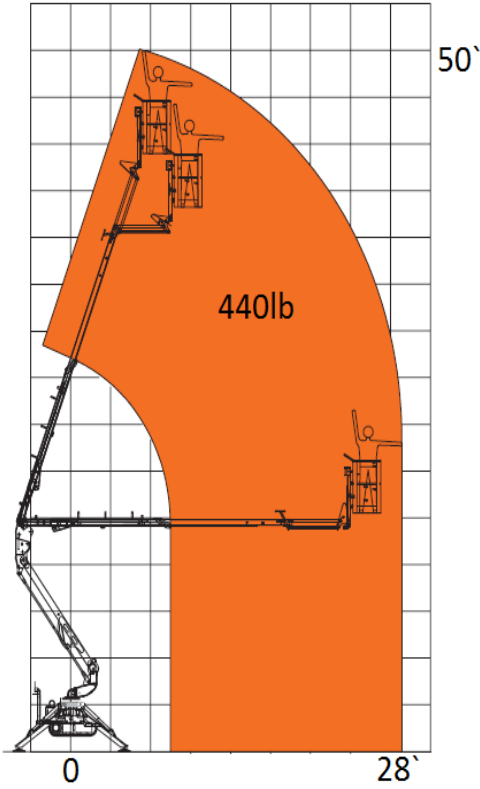

DIMENSIONS

• Working height	50'
• Articulated jib length	5'
• Basket capacity at full height	440 lbs
• Maximum horizontal side reach	
with 440lbs	28'-0"
• Minimum length	
without basket	15'-3"
travel position	17'- 7"
• Minimum width	32.5"
• Basket dimensions (L x W x H)	
Aluminum	44" x 28"
One man fiber	30" x 28"
Two men fiber	44" x 28"
• Turret rotation	340 degrees
• Max slope travel ability	17 Deg or 32%
• Outriggers footprint	12'-9" X 12'-9"
• Total weight diesel	4 630 lbs

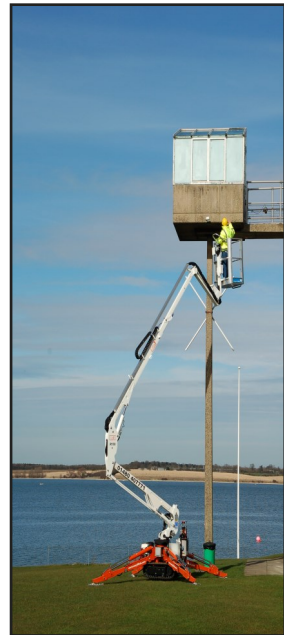

SIDE VIEW

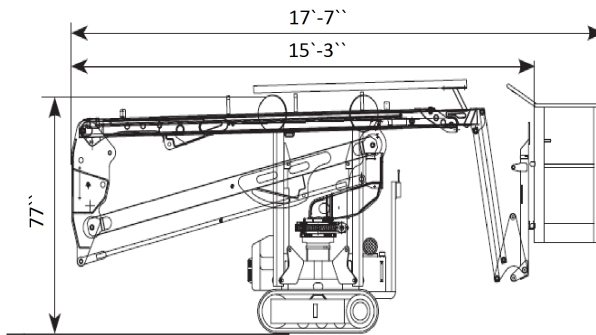

TOP VIEW

