

CB2DCS
1600 lbs [725 kg]

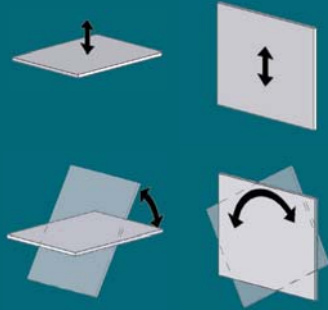

(when used with
 Wood's Powr-Grip's P1-DC,
 P2-DC & MRTALP Series
 vacuum lifters)

**THE ORIGINAL
 & TRUSTED NAME
 IN VACUUM LIFTING
 EQUIPMENT**



908 West Main - P.O. Box 368
 Laurel, Montana 59044 U.S.A.
 406.628.8231 (phone)
 406.628.8354 (fax)

800.548.7341
www.WPG.com



Products are manufactured under an
 ISO 9001 quality management system

Wood's Powr-Grip products are sold
 through authorized dealers.

**CUSTOM DC-POWERED
 COUNTERBALANCE LIFTER
 WITH REMOTE CONTROL**



The CB2DCS Counterbalance Lifter was developed by Wood's Powr-Grip for use with a crane or other hoisting equipment, to lift and position windows under gables, overhangs or similar obstructions, by extending the load away from lift slings. This lifter's unique design features a DC-powered counterbalance, which moves on demand along a rugged I-beam to keep the lifter balanced, whether loaded or unloaded.

COUNTERBALANCE LIFTER

Reach	Minimum: 57¾" [1467 mm] Maximum: 69½" [1766 mm]
Overall Length	148¾" [3766 mm] (Does not include load or optional vacuum lifter)
Maximum Load Capacity	1600 lbs [725 kg] (Including weight of optional vacuum lifter)
Unit Weight	975 lbs [443 kg] (Does not include user-supplied ballast material)
Standard Operating Power	12 volts DC, 58 amps
Features	<ul style="list-style-type: none"> • DC-POWERED COUNTERBALANCE provides effortless counterweight motion, enabling the operator to keep the lifter balanced at all times. • RADIO REMOTE CONTROL enables the operator to control the counterbalance from distances up to 250 ft [76 m] away, as required for window installations in multi-story structures. Note: When paired with remote controlled Powr-Grip vacuum lifters, also syncs with apply and release controls. • FIXED & UNIVERSAL HOOK MOUNTS provide customized, stable attachment of specific Powr-Grip vacuum lifters, plus the flexibility to attach virtually any kind of vacuum lifter or end effector. • BATTERY GAUGE with segmented LED's allows the operator to visually assess the current energy level of the battery and instantly determine whether charging is needed. • AMBER STROBE LIGHT signals to area personnel that a counterweight adjustment is imminent, in case a reaction is required. Note: When paired with remote controlled Powr-Grip vacuum lifters, also warns that load release is imminent. • WHITE INDICATOR LIGHT signals when counterweight has reached the forwardmost position, enabling the operator to release the load remotely with minimal lifter movement.

Environmental conditions can affect product performance and longevity; consult the product instructions on www.WPG.com or contact a Technical Sales Representative for more information.
 Based on product information at time of publication.



CB2DCS Counterbalance Lifter shown in combination with P2110445DC vacuum lifter (reverse-angle orientation).

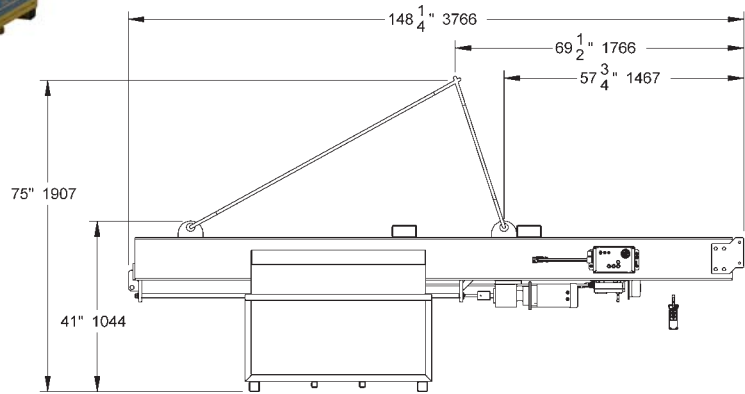

The Counterbalance Lifter comes with radio remote controls, to adjust the counterweight position during multi-story window installations, as well as on-board controls for use on the ground or in a cherry picker. A specialized fixed mount enables the CB2DCS to be used in conjunction with Powr-Grip's P1-DC, P2-DC and MRTALP Series vacuum lifters, while a universal hook mount accommodates all other kinds of vacuum lifters and end effectors. Powr-Grip's Channel Lifters can also be inverted on the Counterbalance Lifter for reverse-angle installations, such as those in airport control towers. In short, the CB2DCS Counterbalance Lifter represents a dramatic improvement in safety, versatility and functionality over other available designs.

VACUUM LIFTERS

Standard Pad Spread	P11004DC: 49" x 10" [1245 x 254 mm] P2110445DC: 51" x 54¼" [1295 x 1378 mm] P211047DC: 51" x 84¼" [1295 x 2140 mm] MRTALP611LDC: 52¾" [1340 mm] x 102" [2593 mm] MRTALPCH611LDC: 79¼" x 12" [2010 x 305 mm]
Load Capacity (On smooth, nonporous surfaces. Please contact us for recommendations on other surfaces.)	P11004DC: 600 lbs [270 kg] P2110445DC: 1400 lbs [635 kg] P211047DC: 1400 lbs [635 kg] MRTALP611LDC: 1100 lbs [500 kg] MRTALPCH611DCS: 1100 lbs [500 kg]
Specification Sheets	P11004DC: 4-1 P2110445DC: 4-2 P211047DC: 4-3 MRTALP611LDC: 8-10 MRTALPCH611DCS: 8-9