

Winlet



1265 WINLET



Don't break your back - or the glass!

- Lifts 1265lbs
- Safer than manual handling
- Self propelled
- Improve job efficiency and work environment
- Access narrow doorways, elevators and balconies
- Twin wheels for rough terrain operations
- Lifts all airtight materials (glass, granite, concrete, steel, tile, fire doors, etc.)

**GOOD
DESIGN**

2011 Winner

THE CHICAGO
ATHENAEUM
MUSEUM OF
ARCHITECTURE
AND DESIGN



ReachMaster, Inc.

www.reachmaster.com

1.866.358.7088

REACH DIAGRAM

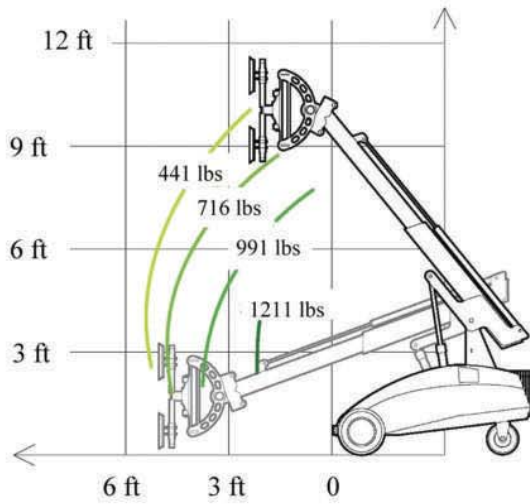

PICKUP AND PLACE DIAGRAM

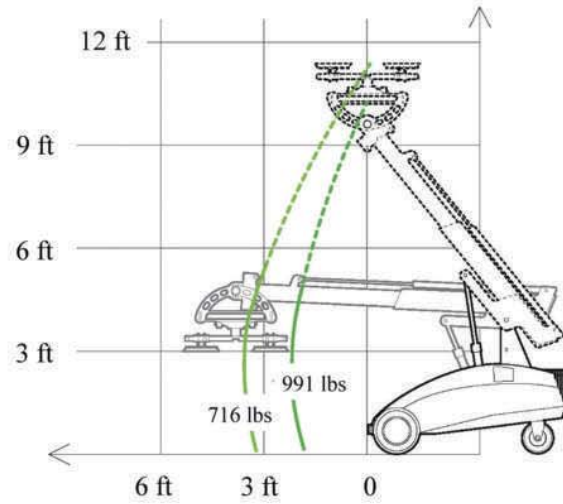

- User friendly
- Easy to transport
- Increase efficiency
- Double action safety keys
- Improve safety on jobsites
- Gyro feature standard
- Increase your bottom line
- Multi functional control box

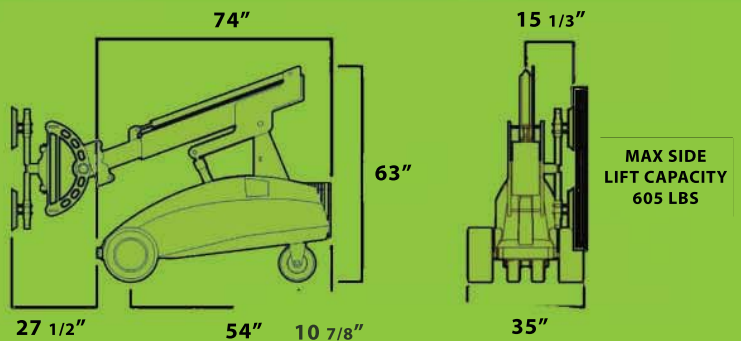

Specifications

External Length	6'2"
External Width	2'11"
Max. Lifting Capacity	1265 lbs
Max Load @ Max Extension	605 lbs
Maximum Capacity on Side	605 lbs
Total Weight (excluding counterweight)	2258 lbs
Total Weight (including counterweight)	2864 lbs
Min. Extension (front bumper to suction cup)	2'3"
Max Extension (front bumper to suction cup)	5'1"
Max Lifting Height (to center of lifting yoke)	11'10"
Hydraulic Side Offset	4"
Fine Lift on Arm	8"
Tilt Function	180°
Hydraulic Rotation	180°
Suction cups	4 x 13 3/4"
Batteries	2 x 150 AH



Superior & Simple Operator Interface

Accessories

- Twin wheels for rough terrain
- Support wheels for extra stability
- Lifting fork for pallets
- Lifting hook for straps
- Forklift Adapter



ReachMaster, Inc
 1416 D Stonehollow Dr.
 Kingwood, TX 77339
 TF: 1-866-358-7088
 Tel: 281-358-7088
 Fax: 281-359-3500
www.reachmaster.com