

1. EDITION
PRODUCTS

INTELLIGENT VACUUM

LIFTING SOLUTION

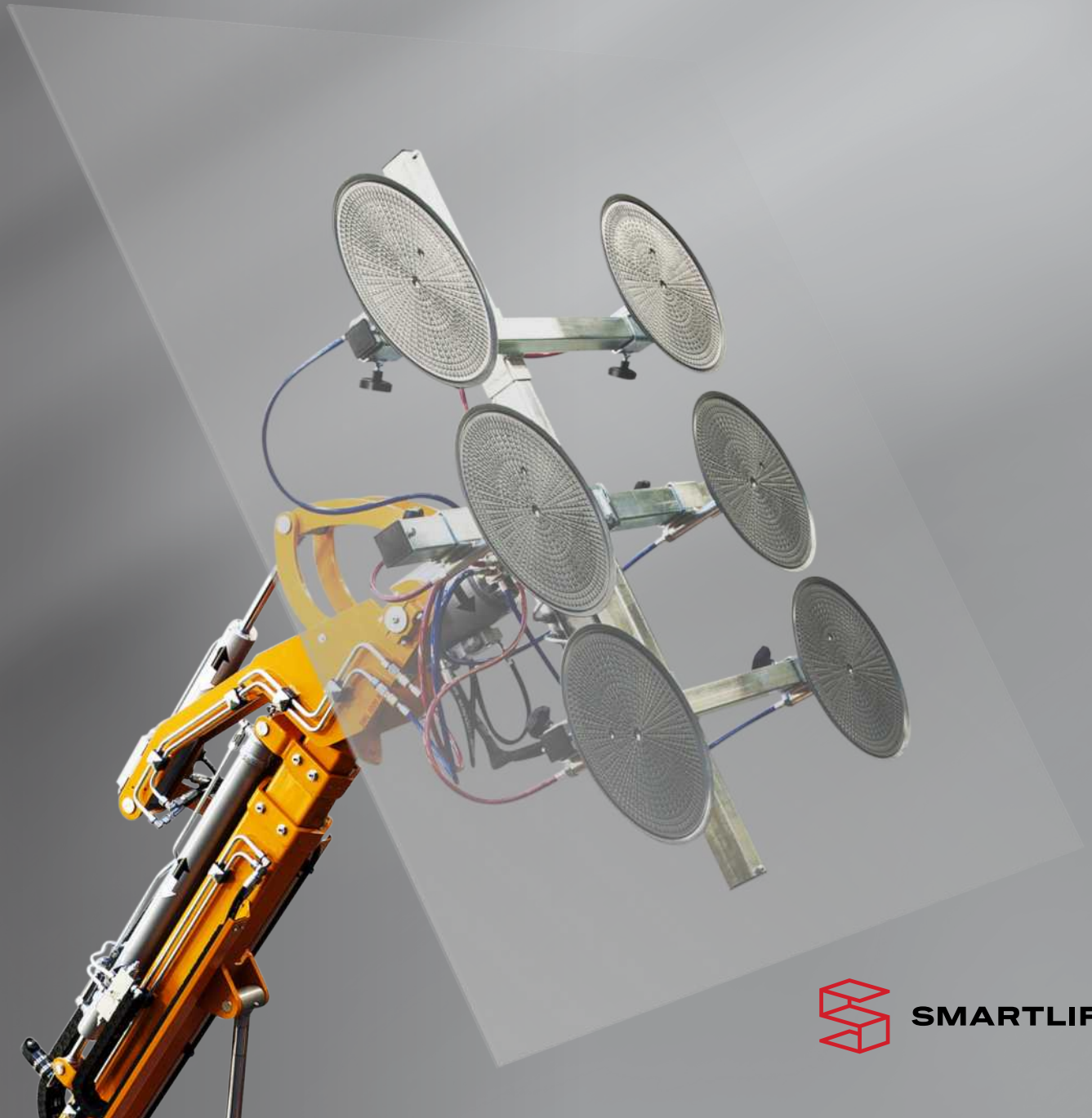

SMARTLIFT®

THE SAFE CHOICE

WORK SMARTER

Having a Smartlift on your team will make you **work faster and safer**. Minimize the risk of injuries from heavy lifting and work up to twice as fast during installation.

In high-rise projects, you will experience **considerable savings** compared to using a large crane outside the building. Simply install from the inside and optimize logistics by placing the glass on each floor during initial construction.

PREFERRED BY PROFESSIONALS

Every component in a Smartlift is carefully selected to ensure maximum **precision, reliability and usability**. This allows for stepless and safe operation of any Smartlift model.

We have full control of the entire supply chain and assembly processes. Therefore, we have the knowhow, flexibility and capability to act quickly and meet customer requirements.

Buying a Smartlift gives you freedom to choose from a variety of factory-installed options. Customize your lift and then add accessories for even greater utilization.

We are experts in vacuum robot technology and we know the value of swift and precise **after-sales support and service**. When you own a Smartlift, we do our best to keep you working without interruption.

JOIN THE REVOLUTION

At Smartlift, we believe that hard work and new ideas combined can drive technology and improve the way that people work. We are committed to revolutionize the glass installation process by making the best glazing robots in the industry.

That's why Smartlift is considered **the safe choice** among professionals all over the world.





HIGHLIGHT

Joystick control:

This lift can turn around its own axis using the joystick.



SL 208 INDOOR

LIFTS UP TO 460 LBS.

The SL 208 Indoor is our most compact and manoeuvrable lift. Easy to control using a joystick and supported by two powerful 1,500W electric motors making the lift capable of rotating on its own axis.

This glass robot is ideal for indoor installation where space might be limited or in industrial production facilities.

TECHNICAL SPECIFICATIONS

Lifting cap. arm in/out	460/330 lbs.
Lifting height	106 in.
Extension of arm	20 in.
Tip from horizontal	54° back / 53° fwd.
Side shift	-
Charging voltage	230 V / 110V
Charging time	Approx. 8 hrs.
Battery (2 x 12V)	2 x 70 Ah
Running period	Up to 10 hrs.
Rear-wheel drive	2 x 1,500 W DC
Brake	Electro-magnetic
Suction pads	4 x Ø7.9 in.
Width	28 in.
Curb weight	1,060 lbs.



TURNING RADIUS
34 INCHES



LIFTING HEIGHT
106 INCHES



Compact in size and tight turning radius

BUILD YOUR SMARTLIFT

Foam-filled tyres	NA
Single Gyro	■
Electric key switch	■
White, non-marking tires	■
Special Color	■
Wireless remote	■
Manual extension of the arm	NA
Electrical extension of the arm	NA
Electrical rotating yoke	NA

■ Select the options you need



HIGHLIGHT

Steering handle:

Most Smartlifts are equipped with an intuitive and ergonomic drive handle.



SL 280 INDOOR

LIFTS UP TO 620 LBS.

The SL 280 Indoor is a compact glass robot with more lifting capacity. The unique feature of this lift is the slim frame width of only 25 in. This is probably the slimmest indoor glazing robot in the market today and it does not compromise on precision and ease of operation.

The rear wheel drive makes it very maneuverable with a tight turning radius. The puncture proof tires provide a secure grip on most surfaces.

TECHNICAL SPECIFICATIONS

Lifting cap. arm in/out	620/350 lbs.
Lifting height	106 in.
Extension of arm	20 in.
Tip from horizontal	50° back / 50° fwd.
Side shift	4 in.
Charging voltage	230 V / 110V
Charging time	Approx. 8 hrs.
Battery (2 x 12V)	2 x 60 Ah
Running period	Up to 10 hrs.
Rear-wheel drive	700 W DC
Brake	Electro-magnetic
Suction pads	4 x Ø12 in.
Width	25 in.
Curb weight	1,050 lbs.



SIDE SHIFT
4 INCHES



LIFTING HEIGHT
106 INCHES



More lifting power in a compact design

BUILD YOUR SMARTLIFT

Foam-filled tyres	NA
Single Gyro	■
Electric key switch	■
White, non-marking tyres	■
Special Color	■
Wireless remote	■
Manual extension of the arm	NA
Electrical extension of the arm	NA
Electrical rotating yoke	NA

■ Select the options you need



HIGHLIGHT

Remote control:

All electric Smartlifts have a wired remote control for adjusting the arm and yoke.



SL 380 INDOOR

LIFTS UP TO 840 LBS.

The SL 380 Indoor is a powerful mid-range vacuum lifter for indoor use and it has sideways shifting up to 10 cm for higher flexibility during installation.

The rear-wheel drive makes the lift very manoeuvrable in narrow corridors and small spaces. Puncture proof tires provide a secure grip on most surfaces.



SIDE SHIFT
4 INCHES



LIFTING HEIGHT
106 INCHES



The SL 380 Indoor combines lifting power and flexible use indoors

TECHNICAL SPECIFICATIONS

Lifting cap. arm in/out	840/460 lbs.
Lifting height	106 in.
Extension of arm	20 in.
Tip from horizontal	45° back / 105° fwd.
Side shift	4 in
Charging voltage	230 V / 110V
Charging time	Approx. 8 hrs.
Battery (2 x 12V)	2 x 60 Ah
Running period	Up to 10 hrs.
Rear-wheel drive	700 W DC
Brake	Electro-magnetic
Suction pads	4 x Ø12 in.
Width	26 in.
Curb weight	1,260 lbs.

BUILD YOUR SMARTLIFT

Foam-filled tyres	NA
Single Gyro	■
Electric key switch	■
White, non-marking tires	■
Special Color	■
Wireless remote	■
Manual extension of the arm	NA
Electrical extension of the arm	NA
Electrical rotating yoke	NA

■ Select the options you need



HIGHLIGHT

Safety first:
Any Smartlift has several safety features built in to prevent overload and accidents.



SL 580 INDOOR

LIFTS UP TO 1,280 LBS.

Do not underestimate this heavy-duty vacuum lifter. The SL 580 Indoor is excellent for handling the heaviest windowpanes, fire doors and sheets of glass without compromising on precision and ease of use.

A slim body width and the rear-wheel drive make it very maneuverable inside buildings or on the factory floor. The puncture proof tires provide a secure grip on most surfaces.

Models: Indoor / High Lifter / High Lifter RT / High Lifter Electric / High Lifter Electric RT



SIDE SHIFT
4 INCHES



LIFTING HEIGHT
102 INCHES



Our most powerful lift for indoor use

TECHNICAL SPECIFICATIONS

Models	SL580 Indoor	SL580 Indoor HL/HLE	SL580 Indoor HL RT/ HLE RT
Lifting cap. arm in/out	2,280/620 lbs.	1,170/190 lbs.	1,060/160 lbs.
Lifting height	96 in.	102 in.	102 in.
Extension of arm	20 in.	63 in.	63 in.
Tip from horizontal	25° back / 105° fwd.	25° back / 105° fwd.	25° back / 105° fwd.
Side shift	4 in.	4 in.	4 in.
Charging voltage	230 V / 110 V	230 V / 110 V	230 V / 110 V
Charging time	Approx. 8 hrs.	Approx. 8 hrs.	Approx. 8 hrs.
Running time	Up to 10 hours	Up to 10 hours	Up to 10 hours
Rear wheel drive	1000 W DC	1000 W DC	1000 W DC
Brake	Electro-magnetic	Electro-magnetic	Electro-magnetic
Suction pads	4 x Ø16 in.	4 x Ø16 in.	4 x Ø16 in.
Width	31 in.	31 in.	31 in.
Curb weight	1,545 lbs.	1,720/1,742 lbs.	1,765/1,786 lbs.

BUILD YOUR SMARTLIFT

Foam-filled tyres	NA
Single Gyro	■
Electric key switch	■
White, non-marking tires	■
Special Color	■
Wireless remote	■
Manual extension of the arm	■
Electrical extension of the arm	■
Electrical rotating yoke	■

■ Select the options you need

SL 208 INDOOR

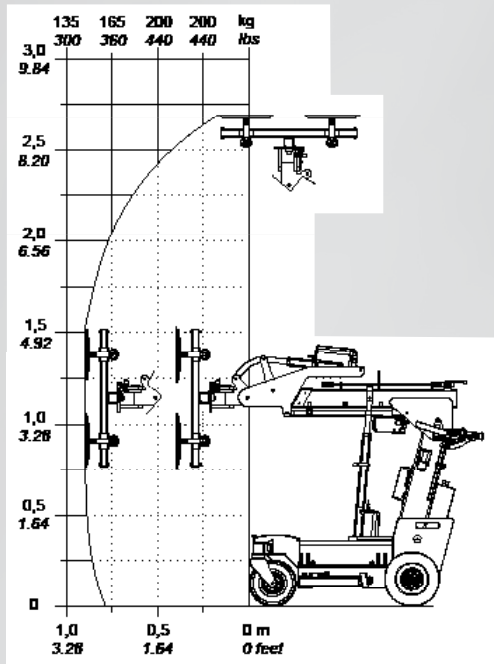

SL 280 INDOOR

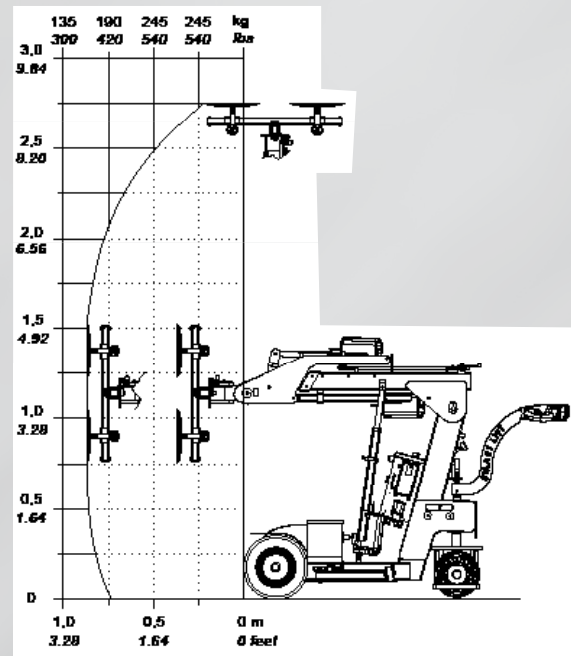

SL 380 INDOOR

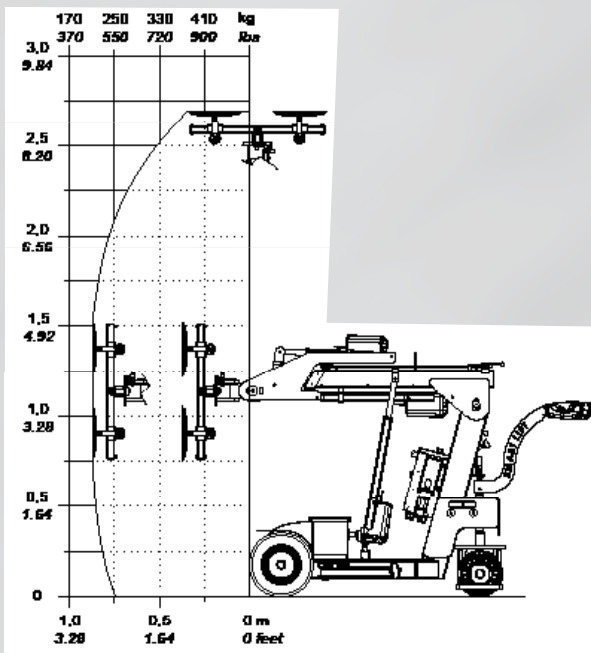

SL 580 INDOOR

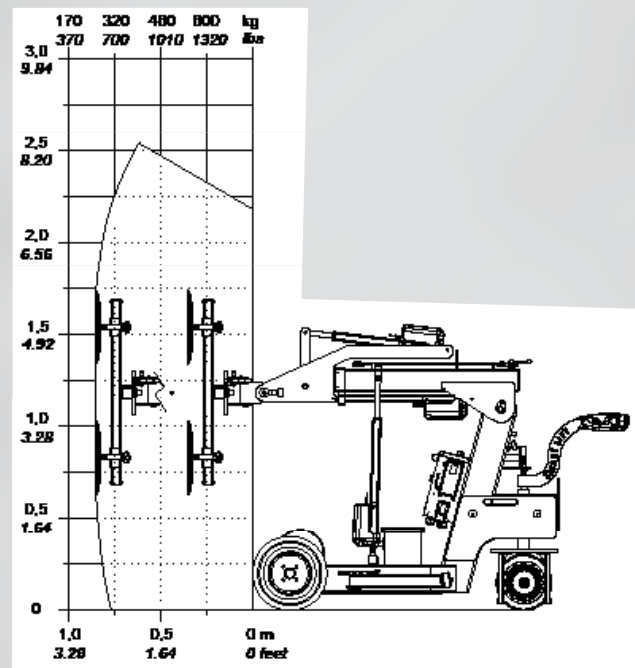



Picture: SL 408 Outdoor

HIGHLIGHT

High Lifter option:
Choose extra manual extension of the arm for longer reach.



SL 408 OUTDOOR SERIES

LIFTS UP TO 840 LBS.

The SL 408 Outdoor series is ideal for construction sites where versatility is key. The combination of lifting power and a compact design makes this lift relevant for glazing outdoor and indoor. Even when carrying a maximum load of 840 lbs., the lift has more than enough power to get the job done.

The 408 series is fitted with wide twin tires to ensure that it does not get bogged down in off-road conditions. The lift is front-wheel driven and fitted with wide, puncture-proof tyres to ensure unique stability when driving with a full load. The lift is also available in a High Lifter version for additional reach.

Models: Outdoor / High Lifter/ High Lifter RT / High Lifter Electric / High Lifter Electric RT

TECHNICAL SPECIFICATIONS

Model	SL 408 Outdoor	SL 408 Outdoor High Lifter	SL 408 Outdoor HL RT / HLE / HLE RT
Lifting cap. arm in/out	840/440 lbs.	840/220 lbs.	950/200 lbs.
Lifting height	110 in.	130 in.	145 in.
Extension of arm	24 in.	24 + 24 in.	24 + 24 in.
Tip from horizontal	45° back/105° fwd.	45° back/90° fwd.	45° back/90° fwd.
Side shift	4 in.	4 in.	4 in.
Charging voltage	230 V/110V	230 V/110V	230 V/110 V
Charging time	Appr. 8 hrs.	Appr. 8 hrs.	Approx. 8 hrs.
Running period	Up to 10 hrs.	Up to 10 hrs.	Up to 10 hrs.
Front-wheel drive	1200 W AC	1200 W AC	1200 W AC
Suction pads	4 x Ø12 in.	4 x Ø12 in.	4 x Ø12 in.
Width	32 in.	32 in.	32 in.
Curb weight	1,390 lbs.	680 kg/1,500 lbs.	Up to 1,600 lbs.
Class	IP 65	IP 65	IP 65



EXTENSION OF ARM
UP TO 47 INCHES



LIFTING HEIGHT
UP TO 128 INCHES



Choose the High Lifter version for additional reach and lifting height

BUILD YOUR SMARTLIFT

	Standard
Foam-filled tyres	
Single Gyro	■
Electric key switch	■
White, non-marking tires	■
Special Color	■
Wireless remote	■
Manual extension (HL)	■
Electrical extension (HLE)	■
Rotation yoke RT (HL RT/ HLE RT)	■

■ Select the options you need



Picture: SL 608 Outdoor High Lifter

HIGHLIGHT

- 1. High Lifter option:**
Extra manual or electrical extension of the arm.
- 2. Electric rotating yoke:**
Stepless 3D movement of the arm and yoke.



SL 608 OUTDOOR SERIES

LIFTS UP TO 1,340 LBS.

SL 608 Outdoor series offers you more power and more options. Choose longer reach and a rotating yoke for more flexibility during installation. One man can easily handle the rotation of large glass sections and experience maximum flexibility during installation.

The 608 series is fitted with twin tires to ensure that it does not get bogged down in off-road conditions. It is front-wheel driven and fitted with wide, puncture-proof tyres to ensure unique stability driving in terrain. The lift is available in a High Lifter version for additional reach and can be fitted with an electric rotating yoke.

Models: Outdoor / High Lifter / High Lifter RT / High Lifter Electric / High Lifter Electric RT

TECHNICAL SPECIFICATIONS

Model	SL 608 Outdoor	SL 608 Outdoor HL/RT + HLE/RT
Lifting cap. arm in/out	1,340/620 lbs	1,340/330 lbs.
Lifting height	134 in.	165 in.
Extension of arm	27 in.	12 ft. 2 in.
Tip from horizontal	40° back / 100° fwd.	40° back / 100° fwd.
Side shift	4 in.	4 in.
Charging voltage	230 V / 110V	230 V / 110V
Charging time	Approx. 8 hrs.	Approx. 8 hrs.
Running period	Up to 8 hrs.	Up to 8 hrs.
Front-wheel drive	1200 W AC	1200 W AC
Suction pads	4 x Ø16 in.	4 x Ø16 in.
Width	33 in.	33 in.
Curb weight	1,875 lbs.	2,050-2,160 lbs.



EXTENSION OF ARM
UP TO 63 INCHES



LIFTING HEIGHT
UP TO 165 INCHES



Customize the lift to fit your exact needs by selecting from the options list below.

BUILD YOUR SMARTLIFT

Foam-filled tyres	Standard
Single Gyro	■
Electric key switch	■
White, non-marking tires	■
Special Color	■
Wireless remote	■
Manual extension (High Lifter - HL)	■
Electrical extension (High Lifter Elec. - HLE)	■
Rotating yoke RT (only HL and HLE)	■

■ Select the options you need



HIGHLIGHT

1. Rotary yoke:
Stepless 3D movement of the yoke and load.

2. Wireless remote:
Control the movement of the arm and load from where you have the best overview

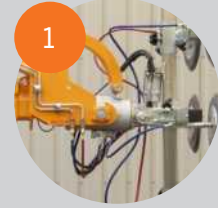

SL 808 OUTDOOR

LIFTS UP TO 1,810 LBS.

The SL 808 Outdoor combines lifting power with an impressive reach. Large window sections are installed easily and precisely using the multifunctional, rotary yoke.

A wireless remote controls all yoke and arm movements and makes it possible for the operator to move around the lift during installation. The lift has a proportional hydraulic system that enables the operator to control the arm with extreme precision so that small adjustments of the controls trigger small movements of the yoke and arm.

The SL 808 Outdoor is fitted with twin tyres to ensure that it does not get bogged down in off-road conditions. The lift is front-wheel driven and fitted with wide, puncture-proof tyres to ensure unique stability when driving with a full load.



EXTENSION OF ARM
65 INCHES



LIFTING HEIGHT
173 INCHES



This lift features proportional hydraulic movement of the arm and yoke.

TECHNICAL SPECIFICATIONS

Lifting cap. arm in/out	1,810 / 440 lbs.
Lifting height	173 in.
Extension of arm	2 x 33 in.
Tip from horizontal	42° back / 86° fwd.
Side shift	4 in.
Charging voltage	230V / 110V
Charging time	Approx. 8 hrs.
Battery	4 x 134 Ah AGM
Running period	Up to 8 hrs.
Front-wheel drive	2000 W AC
Suction pads	4 x Ø16 in. & 2 x Ø12 in.
Width	40 in.
Curb weight	2,860 lbs.
Class	IP 65

BUILD YOUR SMARTLIFT

Foam-filled tyres	Standard
Electric key switch	■
Special Color	■
Wireless remote	Standard
Hydraulic extension of arm	Standard
Hydraulic rotating yoke	Standard

■ Select the options you need



HIGHLIGHT

1. Rotating yoke:
Stepless 3D movement of the yoke and load.

2. Information display:
Monitor battery status, vacuum pressure and load strain on the wireless remote control.



SL 1008 OUTDOOR

LIFTS UP TO 2,200 LBS.

The SL 1008 Outdoor is our most advanced lift. It combines maximum lifting power and reach. Large window sections are easily and precisely handled using the multifunctional, rotary yoke.

The wireless remote controls all functions and offers freedom of movement for the operator. A display gives the operator full overview of battery status, vacuum level and actual load strain. The lift has a proportional hydraulic system that enables the operator to control the arm extremely precise.

The SL 1008 Outdoor is fitted with wide twin tyres to prevent the machine from getting bogged down. The lift is front-wheel driven and fitted with wide tyres to ensure unique stability when driving with a full load.

TECHNICAL SPECIFICATIONS

Lifting cap. arm in/out	2,200 / 620 lbs.
Lifting height	173 in.
Extension of arm	2 x 33 in.
Tip from horizontal	42° back / 86° fwd.
Side shift	4 in.
Charging voltage	230V / 110V
Charging time	Approx. 8 hrs.
Battery	4 x 134 Ah AGM
Running period	Up to 8 hrs.
Front-wheel drive	2000 W AC
Suction pads	Ø16 in.
Width	40 in.
Curb weight	2,860 lbs.
Class	IP 65



EXTENSION OF ARM
65 INCHES



LIFTING HEIGHT
173 INCHES



The SL 1008 Outdoor is the HULK of the Smartlift range

BUILD YOUR SMARTLIFT

Foam-filled tyres	Standard
Electric key switch	■
Special Color	■
Wireless remote	Standard
Hydraulic extension of arm	Standard
Hydraulic rotating yoke	Standard

■ Select the options you need

SL 408 OUTDOOR
(HIGH LIFTER)

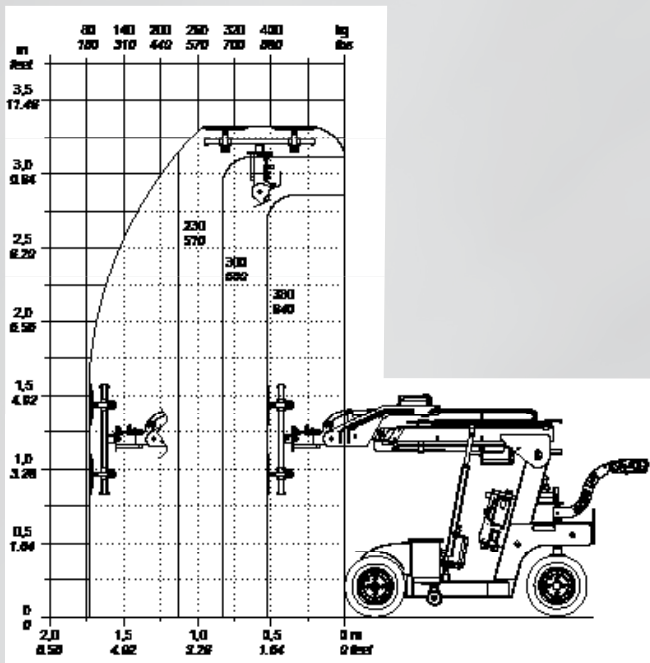

SL 608 OUTDOOR
(HIGH LIFTER ELECTRIC RT)

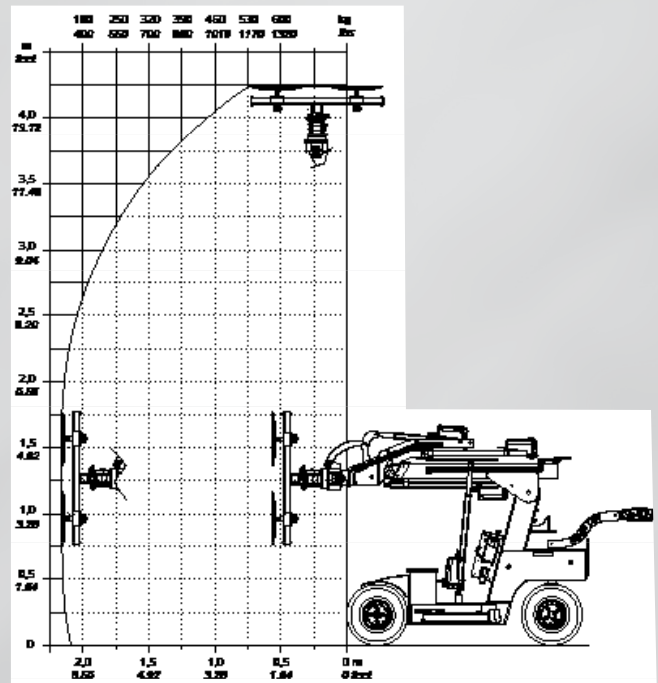

SL 808 OUTDOOR

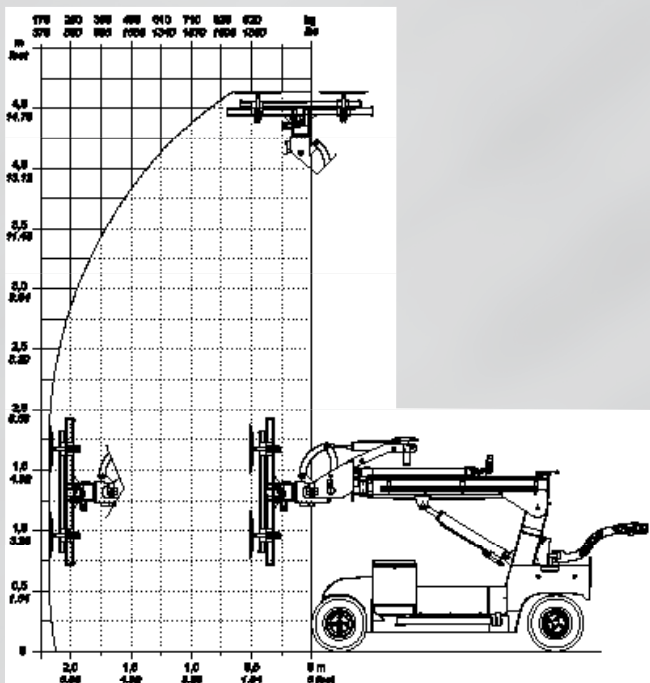

SL 1008 OUTDOOR

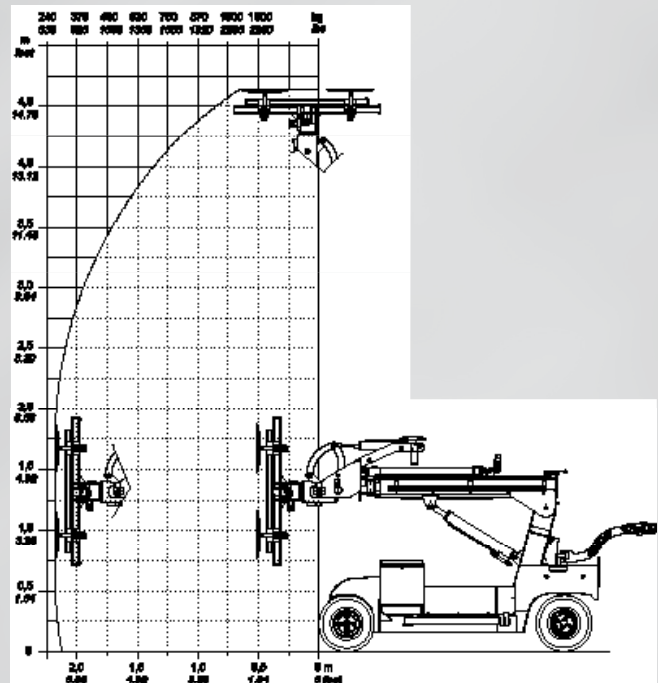

OPTIONS

■ Select the options you need

Build your Smartlift from the factory

	SL 208 Indoor	SL 280 Indoor	SL 380 Indoor	SL 580 Indoor	SL 408 Outdoor series	SL 608 Outdoor series	SL 808 Outdoor	SL 1008 Outdoor
Foam-filled tyres	NA	NA	NA	NA	Standard	Standard	Standard	Standard
Single Gyro	■	■	■	■	■	■	NA	NA
Electric key switch	■	■	■	■	■	■	■	■
White, non-marking tires	■	■	■	■	■	■	NA	NA
Special Color	■	■	■	■	■	■	■	■
Wireless remote	■	■	■	■	■	■	Standard	Standard
Manual extension of the arm	NA	NA	NA	■	■	■	NA	NA
Electrical extension of the arm	NA	NA	NA	■	NA	■	Hydraulic	Hydraulic
Electrical rotating yoke	NA	NA	NA	■	NA	■	Hydraulic	Hydraulic

SELECTED ACCESSORIES

There is a wide range of accessories available for your Smartlift. For more information, call your local dealer or go to our website.



Transport ramp

Aluminium ramps in various sizes for use indoors or outdoors.



Flexolink

Flexible connectors for curved glass. For suction pad up to Ø300mm - up to 12° curve.



Protection cover

Prolong the lifetime of the suction pads.



Suction pad bracket flex

Adjustable bracket with 200 mm adjustment for suction pads.



Lifting hooks

Strong lifting hook with a max. load capacity of up to 400, 600 or 800 kg.



Double suction pad bracket flex

Adjustable double bracket, for oval suction pad. 200 mm adjustment. For curved panes of glass.



SPK suction pads

Suitable for Paroc-and port elements with a rough surface. Replaceable rubber.



Extender type

Suction pad extender. Suitable to attach loads with various levels.



Pallet fork

Various types for every Smartlift model. Max. load capacity of up to 300, 500 or 700 kg.



Cordless remote control - pocket

Available for selected Smartlift models. Replaces the cable remote control.

SPECIAL EQUIPMENT



SL 400 SKY LIFTER RT

LIFTS UP TO 880 LBS.

The SL 400 Sky Lifter RT is a light and flexible electric manipulator which can be mounted on any telescopic loader, crane etc.

The Sky Lifter can rotate 350 degrees without stop using the attached turning head. The rotation is a great advantage during the window installation, because it gives great flexibility.

SL 400 RT is ideal for difficult installations under overhangs or oblique angles. The Sky Lifter is radio-controlled without any limitation of working height.

TECHNICAL SPECIFICATIONS

Lifting cap. arm in/out	880 lbs.
Lifting height	- (depends on parent)
Extension of arm	15 in.
Tip from horizontal	- (depends on parent)
Side shift	8 in.
Charging voltage	230 V / 110V
Integrated charger	No
Charging time	Approx. 4 hrs.
Battery	24V, 20Ah
Running period	Up to 8 hrs.
Suction pads	4 x Ø12 in.
Curb weight	795 lbs.
Class	IP 65



Can be fitted on a telescopic loader for maximum reach



ST 1300 TROLLEY

A rugged and self-propelled transport trolley for plasterboards and other building materials. The Smart Trolley has an electric lifter which extends up to 35 in. above ground level. Can be used as a working bench at the construction site.

- Self-propelled forward/reverse
- For indoor and outdoor use
- Quality bearings
- Independent wheels
- Poly-filled tires
- Indicator for low voltage
- IP65 classified dust and moisture proof

TECHNICAL SPECIFICATIONS

SWL / rated load	2,866 lbs.
Floor dimensions	74 x 28 in.
Floor height	24 - 35 in.
Total length	112 in.
Total length (shipped)	83 in.
Wheel base	57 in.
Extension - handlebar	9 in.
Ground clearance	6 in.
Raise / lower floor	10 sec. / 8 sec.
Driving speeds	Floor raised = 0,6mph. Floor lowered = 4 mph.
Battery	2 x 12V 95Ah AGM
Operation time	Approx. 8 hrs.
Turning radius	10 ft. 2 in.
Charger with indicator	Integrated 110V / 230V
Curb weight	990 lbs.



LIFTING CAPACITY
2,866 LBS.



LIFTING HEIGHT
35 INCHES

”

With a Smartlift, the ergonomics are fantastic. I work every day between 06:00 and 19:00, and even after a long working day I don't feel any pain in my body, because the Smartlift handles all the heavy lifts during the window installation.

– Martin Vestergaard, carpenter.

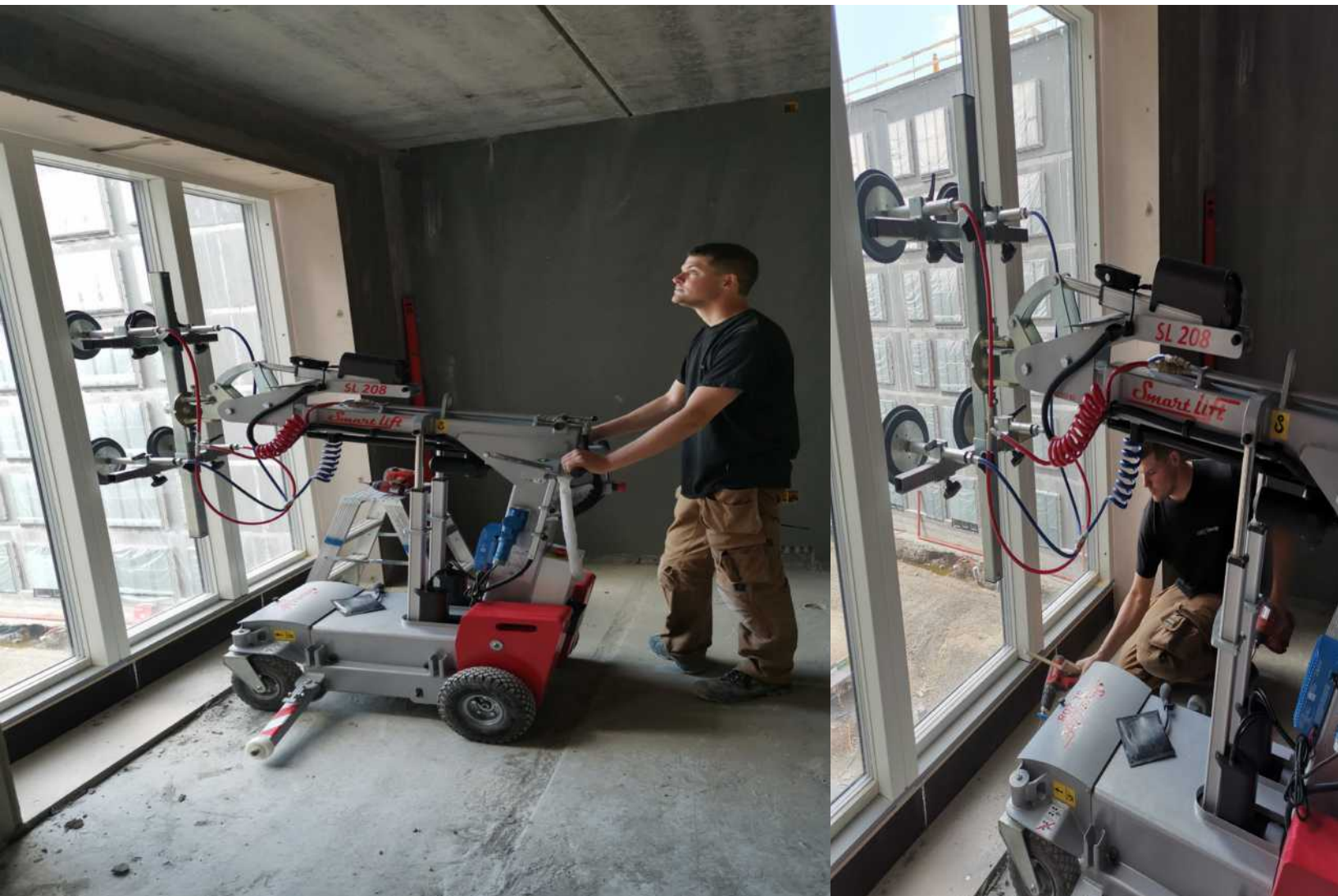

The carpentry firm DN Tømmer A/S uses two SL208 Indoor Smartlifts for window installation on the ambitious urban development project Frederiksbro Stage 2. This is a completely new district in the city Hillerød with 1,300 homes, and is one of the biggest housing projects in Denmark.



CONTACT US

N.A. Christensensvej 39
DK - 7900 Nykøbing Mors
Denmark

T +45 97 72 29 11
E smart@smartlift.com
W smartlift.com