

MAX REACH POSITION:

A	B	C	D*	D1**	E*	E1**
18	20'	20'	1'-3"	1'-4"	9'-1"	9'-9"
20	20'-11"	19'-7"	1'-2"	1'-4"	8'-10"	9'-7"
25	23'-3"	18'-7"	1'-1"	1'-3"	8'-4"	9'
30	25'-5"	17'-4"	10"	1'-3"	7'-10"	9'-2"
35	27'-4"	15'-6"	1'-1"	1'-7"	7'-2"	8'-6"
40	29'	13'-5"	1'-3"	1'-10"	6'-6"	7'-9"
45	30'-6"	11'-4"	1'-4"	2'	5'-10"	7'

* LOWER CHUTE IN LINE WITH MAIN CHUTE

** LOWER CHUTE IN MAXIMUM RECOMMENDED UPWARD POSITION

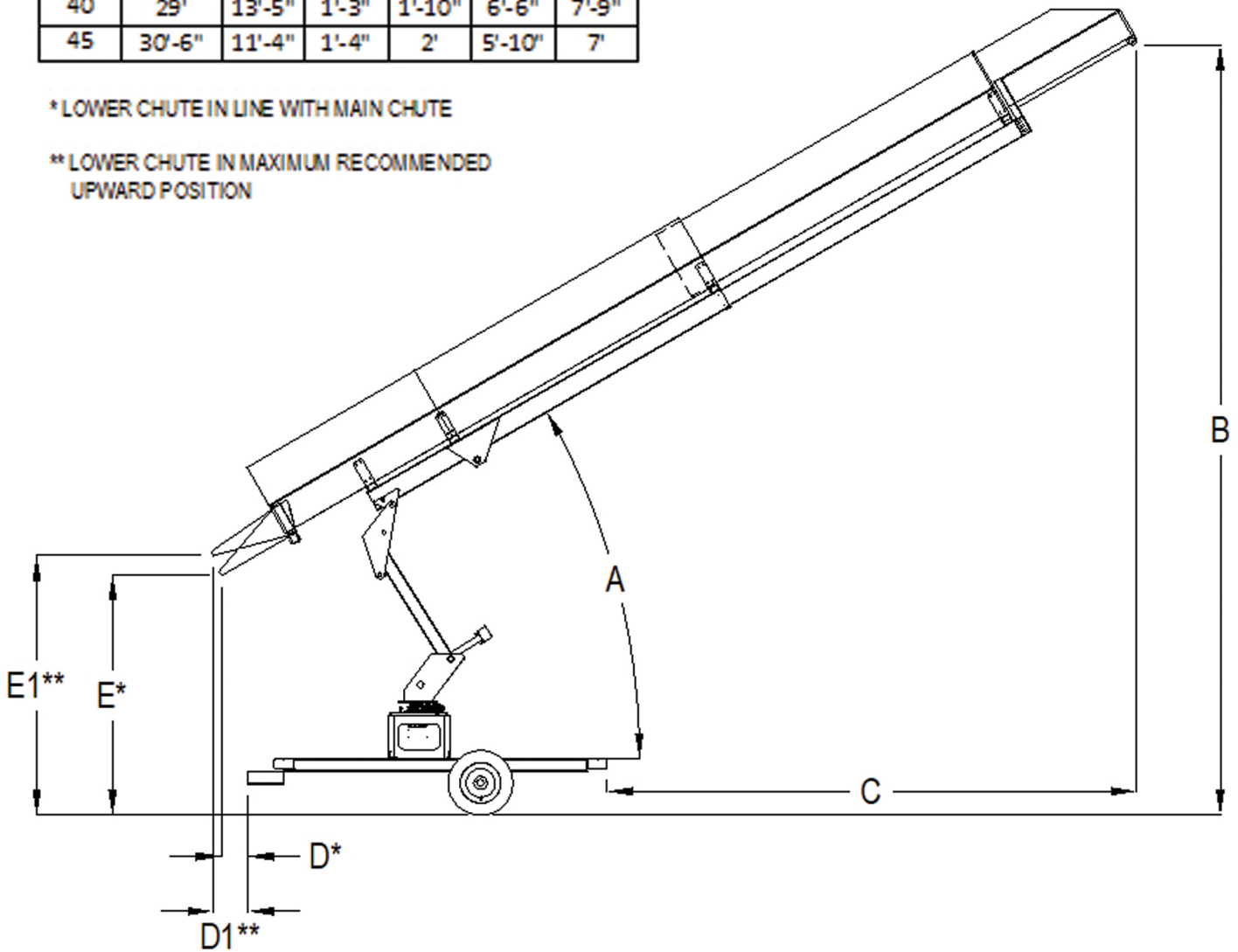

DUMPSTER CLEARANCE POSITION:

A	B	C	D*	D1**	E*	E1**
18	16'-3"	16'-8"	4'-7"	4'-8"	5'-3"	5'-11"
20	17'-2"	16'-4"	4'-6"	4'-8"	5'-1"	5'-9"
25	19'-5"	15'-3"	4'-4"	4'-7"	4'-6"	5'-2"
30	21'-7"	14'	4'-2"	4'-7"	4'-1"	5'-5"
35	23'-8"	12'-7"	4'	4'-6"	3'-7"	4'-10"
40	25'-7"	11'	3'-8"	4'-4"	3'-1"	4'-4"
45	27'-5"	9'-3"	3'-5"	4'-1"	2'-8"	3'-11"

* LOWER CHUTE IN LINE WITH MAIN CHUTE

** LOWER CHUTE IN MAXIMUM RECOMMENDED UPWARD POSITION

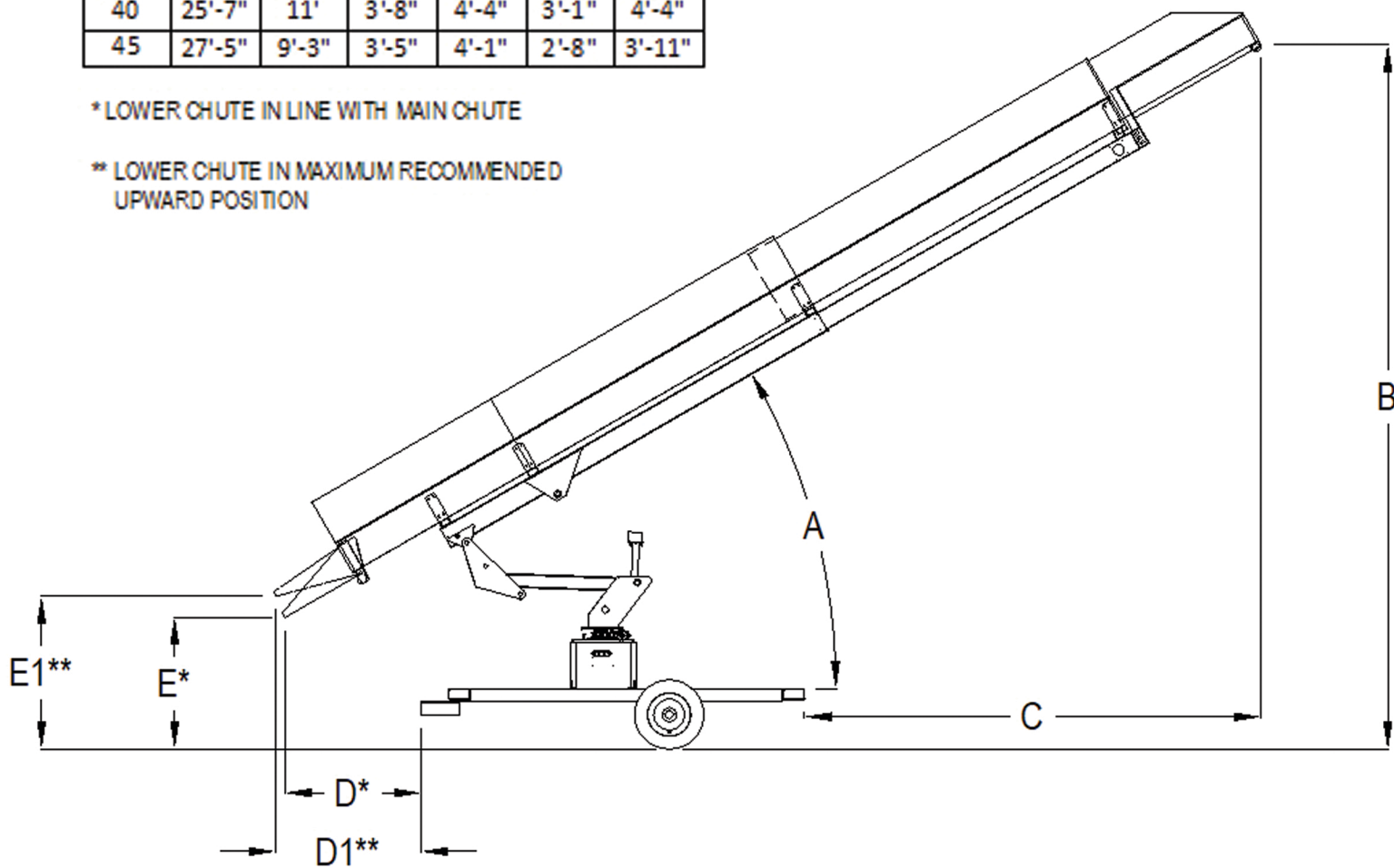

TOWING & STORAGE POSITION:

